

OPERATION MANUAL

PLEASE READ THIS OPERATION MANUAL CAREFULLY BEFORE USE AND FILE FOR FUTURE REFERENCE.

Multi Function Ultrasonic Scaler

FORZA V3

RX ONLY

 **BRASSLER USA**[®]
DENTAL INSTRUMENTATION

TABLE OF CONTENTS

1. Component Names	3	9. Holder	10
2. Name and Function of Each Part	4	10. Care and Maintenance	10
3. Prior to Operation	4	11. Sterilization	11
4. Mounting and Removing the Handpiece	6	12. Troubleshooting	12
5. Mounting and Removing Tip	7	13. Spare Parts	13
6. Operating Procedures	7	14. Disposing Product	13
7. How to Use the Tip Card	9	15. Warranty	13
8. How to Use the Tip Cover	9	16. Symbols	14



SPECIFICATION

TYPE	Forza V3/Forza V3 LED		
POWER SOURCE	AC 100 - 240 V 47 - 63Hz		
VIBRATION FREQUENCY	28 - 32 kHz		
MAXIMUM OUTPUT	11 W		
RATED POWER	25VA		
LIGHTING	Forza V3: No	Forza V3 LED :Yes	
DIMENSION	W 80 × D 115 × H 32 mm (Body without knob and cord)		
WEIGHT	0.43 kg (Except Attachment)		
USE ENVIRONMENT	Temperature: 0 - 40 °C (32 - 104 °F) Atmospheric Pressure: 700 - 1060 hPa	The liquid must not freeze	Humidity: 30 - 75 %
STORE ENVIRONMENT	Temperature: 0 - 60 °C (32 - 140 °F)	Humidity: 10 - 85 %	Atmospheric Pressure: 500 - 1060 hPa

Brasseler U.S.A. Dental, LLC hereinafter will be referred to as "Brasseler USA."

OPERATION MANUAL

CLASSIFICATIONS OF EQUIPMENT

- Type of protection against electric shock:
 - Class II equipment 
- Degree of protection against electric shock:
 - Type BF applied part: 
- Method of sterilization or disinfection recommended by Brasseler USA
 - See page 11, Sterilization
- Degree of protection against ingress of water as detailed in the current edition of IEC 60529:
 - Foot Control: IPX1 (Protected against vertically falling water drops)
- Degree of safety of application in the presence of a flammable anesthetic mixture with air or with oxygen or nitrous oxide:
 - EQUIPMENT not suitable for use in the presence of a flammable anesthetic mixture with air or with oxygen or nitrous oxide.
- Mode of operation:
 - Continuous operation



INTENDED USE

This product is intended only for dental clinic/dental office use. This device generates ultrasonic waves intended for use in dental applications such as scaling, root canal treatment, periodontal and cavity preparation.

RX ONLY CAUTION: U.S. Federal law restricts this device to sale by or on the order of a dentist.

CAUTIONS FOR HANDLING AND OPERATION

- Read these cautions carefully and use only as intended or instructed.
- Safety instructions are intended to avoid potential hazards that could result in personal injury or damage to the device. Safety instructions are classified as follows in accordance with the seriousness of the risk.

CLASS	DEGREE OF RISK
 WARNING	A hazard that could result in bodily injury or damage to the device if the safety instructions are not followed.
 CAUTION	A hazard that could result in light or moderate bodily injury or damage to the device if the safety instructions are not followed.
 NOTICE	General information needed to operate the device safely.

* OPERATION PRINCIPLE

A sinusoidal electrical signal, at ultrasonic frequency ($f > 20\text{kHz}$), is delivered by the generator. This signal is applied to the 'piezoelectric ceramic' located inside the transducer. Piezoelectric ceramic converts this signal into mechanical vibrations. These vibrations are at the same ultrasonic frequency as the electrical signal. The mechanical vibrations are propagated towards the distal end of the transducer. The "TIP" insert, which is attached at the distal end of the transducer, vibrates at ultrasonic frequencies and makes it possible to achieve the aimed purpose.

WARNING





- TO PREVENT ELECTRIC SHOCK Do not unplug the AC Adaptor with wet hands.
- TO PREVENT ELECTRIC SHOCK Be sure to avoid water on the Control Unit.
- TO PREVENT ELECTRIC SHOCK Do not touch the handpiece backend electrical connections.
- TO PREVENT ELECTRIC SHOCK Use an electrical outlet that is grounded.
- If you feel any abnormality such as heat generation or abnormal noise prior or during the use of the unit, stop using it immediately.
- This product is Medical Electrical Equipment Electromagnetic Compatible (EMC). As described in the accompanying documentation.
- Portable and mobile RF (Radio Frequency) communications equipment can affect Electrical Medical equipment. Do not use RF equipment in close proximity to the product.
- When installing the product, provide space of approximately 10cm (0.4 inches) around the Control Unit for easy access to the inlet and the AC Adaptor.
- USE ONLY Brasseler or NSK Tips when using the Brasseler Forza V3 Ultrasonic scaler; Problems such as damage and failure resulting from use of Non-Brasseler or Non-NSK Tips are not included in the warranty. The following are the possible failures that could happen when using Non-Brasseler or Non-NSK Tips:
 - Vibration failure caused by using non conforming screws.
 - Patient accidental ingestion of broken Tips.
 - Damage to the threading of the handpiece
- You must use the Tip within the power range described on the Tip-Power Guide. If you use it out of the power range, the Tip might break or damage the operative site.
- When operating the product always consider the safety of the patient.
- Use by medical professional, such as doctor or dental hygienist, is intended.
- Check the vibration outside the patient's oral cavity before use. If any abnormalities are found, stop using immediately and contact Brasseler USA.
- Do not drop, hit, or subject Control Unit/Handpiece to excessive shock.
- To prevent possible tooth plane damage and handpiece overheating, always use with sufficient water.
- Do not sterilize by ultraviolet light. Handpiece could discolor.
- Sterilize the Tip, Handpiece, Tip Holder, Tip Cover S and Tip Wrench by autoclaving. Wipe the Control Unit, Tip Holder, Tip, AC Adaptor, Foot Control and Handpiece Cord including the cover.
- If chemical, solvent or antiseptic solution is deposited on this product, immediately wipe it away. Discoloration or deformation may occur if not removed.
- Do not disassemble or alter the handpiece/Control Unit.
- Keep away from patients with cardiac pacemakers.
- Keep away from explosive substances and flammable materials. Do not use on patients anesthetized under Nitrous oxide.
- This product needs special precautions regarding EMC and needs to be installed and put into service according to the EMC information.
- The use of ACCESSORIES, transducers and cables other than those specified, with the exception of transducers and cables sold by the manufacturer of this product as replacement parts for internal components, may result in increased EMISSIONS or decreased IMMUNITY of this product.
- This product should not be used adjacent to or stacked with other equipment. If adjacent or stacked use is necessary, this product should be observed to verify normal operation in the configuration in which it will be used.
- If any water drops remain on the handpiece or handpiece cord after autoclaving, wipe them off. Staining may result if not removed.
- User judgement is required when using this product.
- Eye damage may result if the LED is stared directly into. Do not look into or turn it to the eyes of the patient.

CAUTION

- During operation, high frequency oscillations in the handpiece and handpiece cord may affect computer and LAN Noise may be heard during operation near a radio receiver.
- Be sure to turn off the Power/Volume Knob after use. Remove the AC Adaptor and water inside of the Control Unit before storage.
- Users are responsible for operational control, maintenance and inspection.
- Clean/sterilize the product immediately after using it. Then store it. Leaving it non-sterile might lead to failure.
- When you have not used the product for an extended period of time and use it again, check the operation before use.
- When abnormalities are found with a Control Unit and /or an AC adaptor, pull the AC adaptor from AC Outlet immediately.
- This product does not consider patient's age (except infants), gender, weight or nationality.
- No special training is required for this device.
- Applied parts for patient and/or operator are Tip and Handpiece.

I. COMPONENT NAMES

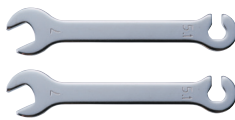
	Control Unit (Handpiece Cord Unshielded 2M)
	Handpiece
	Control Unit Bracket Holder
	AC Adaptor (Unshielded cord 5 feet)
	Handpiece Holder
	Set Screw (Quantity-3)
	Foot Control (Unshielded 12 feet)

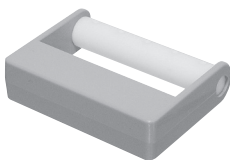
	Water Tube Set
	Rubber Pad (Quantity-4)
	Tip Wrench
	Spanner Wrench (5x8) (Quantity-2)
	O Ring (Quantity-2)
	Tip Cover S (Optional)
	Tip Holder (Optional)

2. NAME AND FUNCTION OF EACH PART

FRONT SIDE (CONTROL UNIT WITH CONTROL UNIT HOLDER)

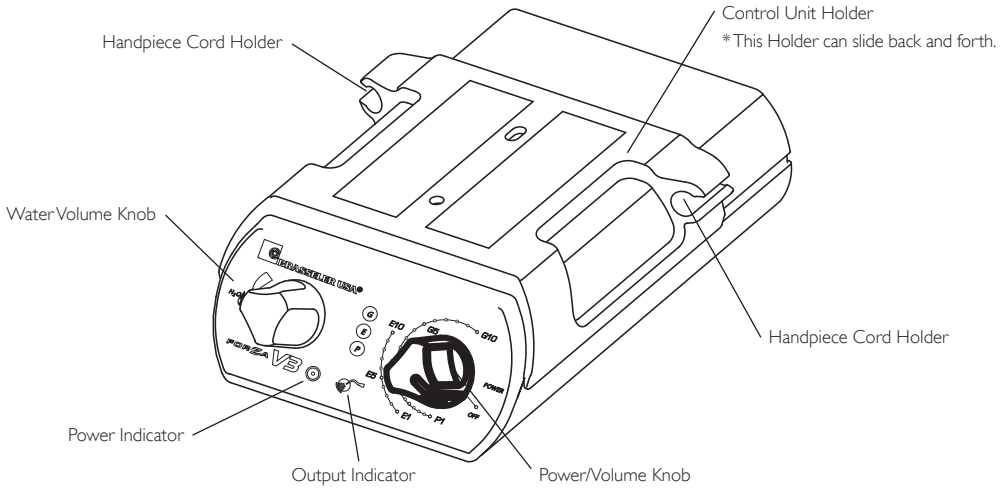

BACK SIDE

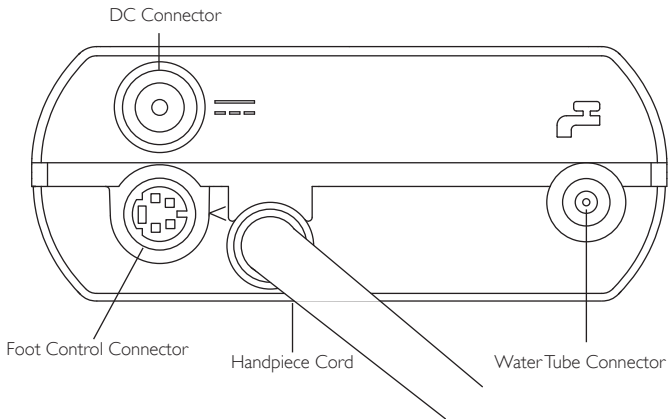

3. PRIOR TO OPERATION

3-1 SET THE AC ADAPTOR

Insert each plug into appropriate connector:

- 1 Set the AC Adaptor head like image on right.
- 2 Slide the Plug Head to the AC Adaptor:

To release, push the Release Button shown on the right, and remove the Plug Head from the Adaptor Body.

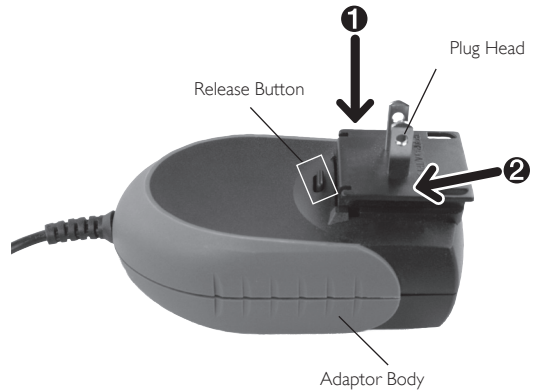

3-2 CONNECTING

Insert each plug into appropriate connector: **(Fig.1)**

- 1 Align the "△" Mark on the Foot Control Connector and Foot Control Plug and connect those firmly.
- 2 Connect Water Tube firmly into Water Tube Connector.
- 3 Connect AC Adaptor into DC Connector:

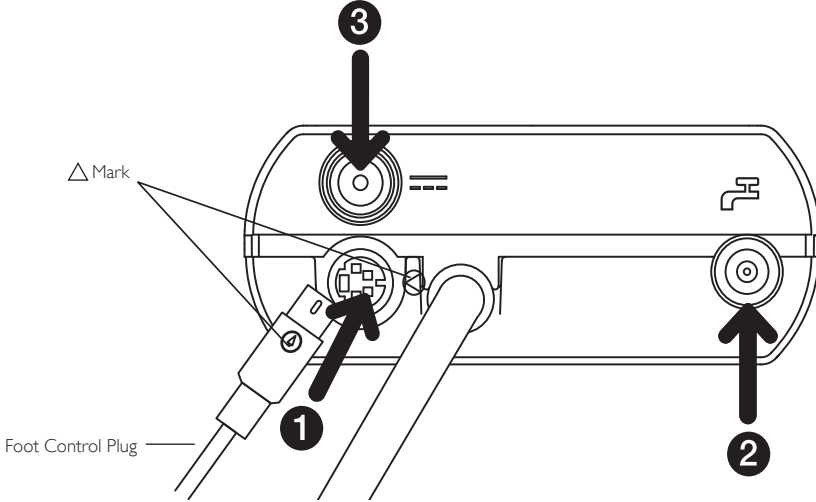

Fig.1

⚠ CAUTION

- Insert plugs firmly into the connector. A loose connection may cause a malfunction.
- Ensure Power is OFF on the Control Unit during the AC Adaptor Connection.
- Do not connect the cord in wall outlet before connecting DC Connector:
- Do not pull the AC Adaptor with force.
- Do not disconnect the AC Adaptor while pressing on the Foot Control.
- Turn OFF the power to connect or disconnect the cords and plugs.

3-3 DISCONNECTING

3-3-1 DC Plug and Foot Control Plug Simply pull out plugs from the Control Unit.

3-3-2 Water Tube **(Fig. 2)**

Pull out the Water Tube while pushing the White Ring.

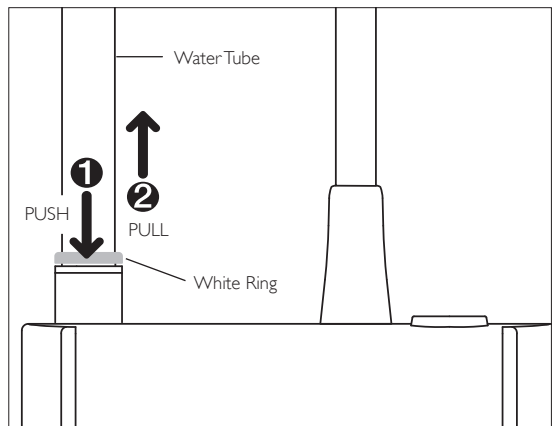

Fig.2

⚠ CAUTION

Water should be removed prior to disconnecting the water tube.

3-4 HANDPIECE HOLDER (Fig.3)

The handpiece holder attached to the Control Unit keeps the handpiece in place when it is not in use. To mount the Handpiece Holder on a vertical surface follow the procedures below.

- 1 Make a 3 mm hole in the Double-Face tape behind the screw hole in handpiece holder.
- 2 On the vertical surface make a 3.2~3.5 mm hole in the plate where the holder will be mounted. Align the hole with the screw hole on the holder. Make certain the surface is clean then adhere the holder to the plate, and attach. Insert the Set Screw through the two holes on the holder and the plate. Fasten the Set Screw with the Nut from the rear of the plate.

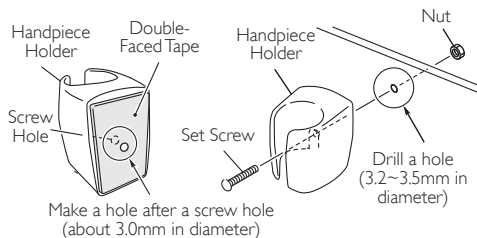

Fig.3

3-5 HANDPIECE CORD HOLDER AND CONTROL UNIT HOLDER (Fig.4)

The Control Unit can be attached to the chair unit using the control unit holder:

- 1 Align the chaser and Slide the Control Unit into the Control Unit Holder.
- 2 Tuck the Handpiece Cord into Handpiece Cord Bracket.
- 3 Peel off the Double-Face Tape cover and put the Control Unit Bracket under the Table or Tray.

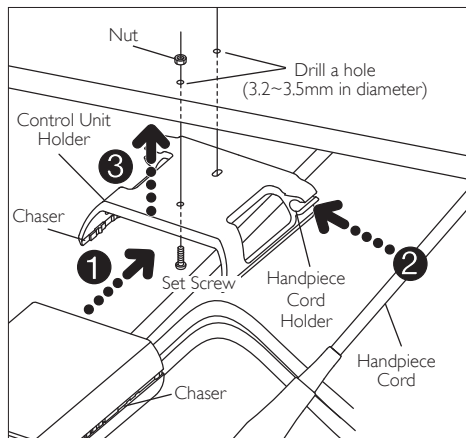

Fig.4

CAUTION

- Do not pull the Handpiece cord with force as it might cause the water tube inside of the Handpiece to bend and result in improper water flow.
- You can mount Control Unit Bracket on the Top Surface or Bottom Surface.

3-6 RUBBER PAD

When using the Control Unit on a stand, make sure to attach rubber pads to the Control Unit before use to prevent slipping. To stop slipping the Control Unit on the table, mount the Rubber Pad at the bottom of it.

- 1 Clean bottom of the Control Unit.
- 2 Fit the Rubber Pad to the appropriate place. (Fig.5)

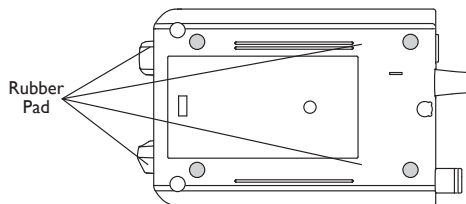

Fig.5

CAUTION

Control Unit Bracket can not be mounted on the bottom surface if the rubber pads are attached.

4. MOUNTING AND REMOVING THE HANDPIECE

Align the Dots on the Handpiece and the Handpiece Cord. Push handpiece into connector.

To remove the handpiece, grip the handpiece and plug of the handpiece cord then pull straight out. (Fig. 6)

WARNING

To avoid Electrical Shock DO NOT touch the handpiece backend electrical contacts.

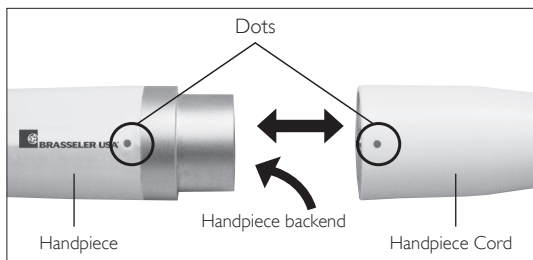

Fig.6

CAUTION

Always confirm that the handpiece is correctly seated and locked into place.

5. MOUNTING AND REMOVING TIP

- 1 Place tip on the threaded post of the handpiece and turn lightly by hand.
 - 2 Insert Tip through the bottom hole of the Tip wrench. Align the four corners of the Tip base area into the four corners of Tip Wrench. And turn it clockwise until it clicks.
- * To avoid injury, do not touch the top part of the Tip.
- 3 To remove the Tip, turn it counterclockwise with the Tip Wrench.

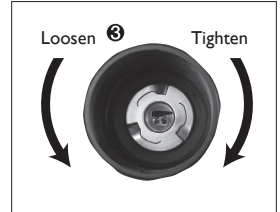
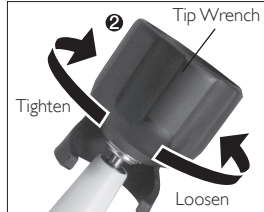
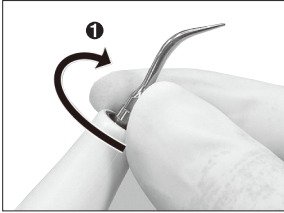

Fig.7

⚠ CAUTION FOR TIP USAGE

- Before using check the tip for damage, bending or rust.
- Do not exceed Maximum Power Level for Tip. Damage to tooth structure and Tip may result.
- Do not hit metal or prosthetic crown, except for removing them. Tip could break and fall into mouth.
- Do not hit gingival, mucosa and/or skin directly. It could cause damage and/or burn injury.
- Do not sharpen and/or bend the Tip. Tip may damage and not generate enough vibration during scaling.
- During cutting, Tip will gradually wear away. As the Tip wears, the stroke will get smaller and decrease cutting efficiency. When level drops too far, change the Tip. (Tip Card check) **(Fig. 14)**
- When securing the Tip, use the Tip Wrench or inefficient cutting will result.
- Before attaching Tip, ensure the Tip post is free of debris or inefficient cutting will result.
- To avoid personal injury ENSURE the Tip is removed prior to disconnecting the handpiece or the handpiece cord.
- If you feel the Tip is not vibrating, remove it from an operative site, and press the Foot Control again. If this does not improve the condition, Ensure the Tip is secure, turn the power off and restart it.
- Ensure that water volume is at "0", when using a Tip without water ports.
- Tip Wrench is disposable component. For reliable operation replace annually.

6. OPERATING PROCEDURES

6-1 POWER ON (Fig.8)

Connect the AC Cord to the wall outlet. Rotate the Power/Volume Knob on the Control Unit. (Power indicator will light on.)

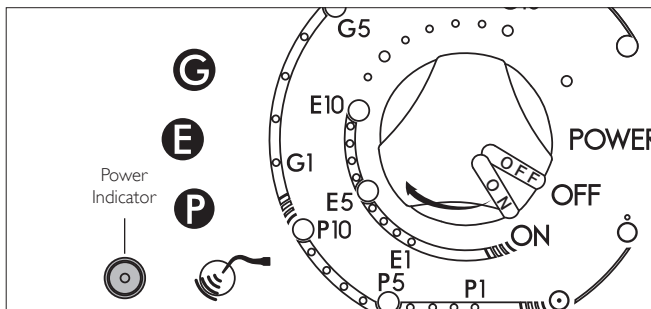

Fig.8

6-2 POWER LEVEL SETTING

Power setting should not exceed the recommended Power Level (Tip-Power Guide included in the package.) Set the power level with the Power/Volume Knob on the Front Panel. Make sure the power level is set in the appropriate range for the attached Tip.

* Power Level for each mode

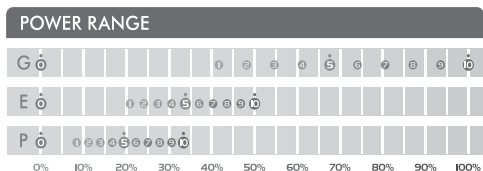

Fig.9

NOTICE

- Rotating the Power/Volume Knob will increase or decrease the Power Level.
- If the Power Level is 0 (zero) and the water volume control is on, the Tip will not oscillate but water will come out from the handpiece.

6-3 OPERATE FORZA V3 LED

The tip vibration will begin when the Foot Control is depressed but the output indicator should also be turned on. (Forza V3 LED Handpiece will illuminate)

6-3-1 WATER SUPPLY VOLUME ADJUSTMENT

Turn the Water Adjustment Knob clockwise gradually to increase the supply volume. (Fig. 10)

- ◆ The Power Level and water can be adjusted while the handpiece is in operation.

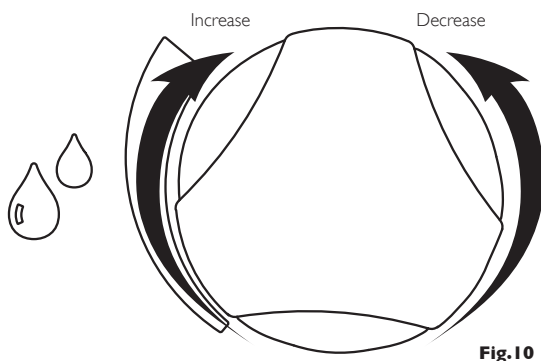

Fig.10

6-4 AFTER THE TREATMENT

Release the Foot Control and Power off the Control Unit. Close the dental unit's water valve.

NOTICE

LED of the handpiece will remain illuminated for approx 5 seconds after Foot Control is released (Forza V3 LED).

6-5 PROTECTION CIRCUIT

The control unit may overheat if used in the "G" mode with a Power Setting of 8 or more for an extended period of time. If this happens the protection circuit will reduce the power automatically to Power 7. If you need Power 8 or higher, decrease to Power Source, and then increase again. Maximum output can be restored by turning the device off for 15 minutes or longer.

NOTICE

During Protection Circuit function, the Control Unit can not increase the Power Level more than 8.

7. HOW TO USE THE TIP CARD

- 1) Place the neck of the Tip in the cut out.
- 2) Check wear of the Tip.
- 3) See the green, yellow and red line to check wear of the Tip. *See below what each color means: We recommend replacing a Tip when the Tip meets the yellow line (wear of 1mm) to guarantee safe and effective use.

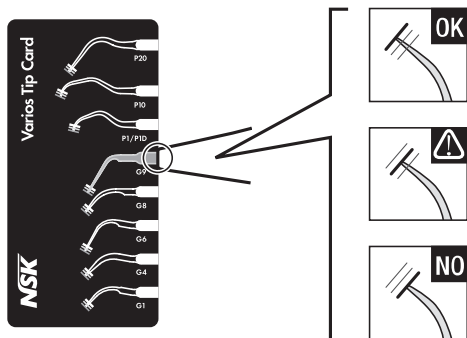

Fig. 14

Green: No wear - Tip is OK
Tip replacement is not necessary.

Yellow: Wear of 1mm - Tip is showing some wear
Tip replacement is recommended.

Red: Wear of 2mm - Tip is badly worn
Tip replacement is necessary.

*The Tip Card can be used to check the following tips : G1, G4, G6, G8, G9, P1/P1D, P10, and P20

⚠ CAUTION

Tips are disposable components. The efficiency of dental scaling decreases approximately 25% when the top of the Tip wears 1 mm and approximately 50% when it wears 2 mm. In addition, the vibration condition changes due to wear; which may damage a patient's tooth surface. Check the Tip wear condition with the Tip Card periodically, and replace the Tip with a new one when needed.

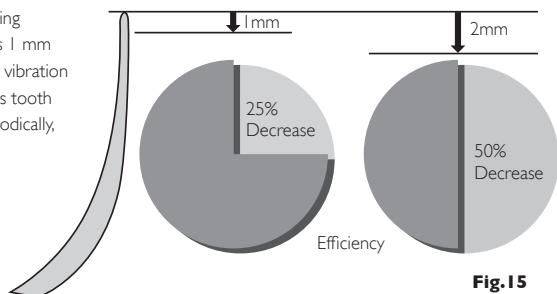

Fig. 15

8. HOW TO USE TIP COVER S (OPTIONAL)

Grip the Tip Cover S and insert it to the Tip. To remove, grip the Tip Cover S and the handpiece & pull. **(Fig. 16)**

⚠ CAUTION

Carefully insert the Tip into the Tip Cover S. Avoid injuring the fingers.

* The Tip Cover S is not designed for use as a Tip changing tool.

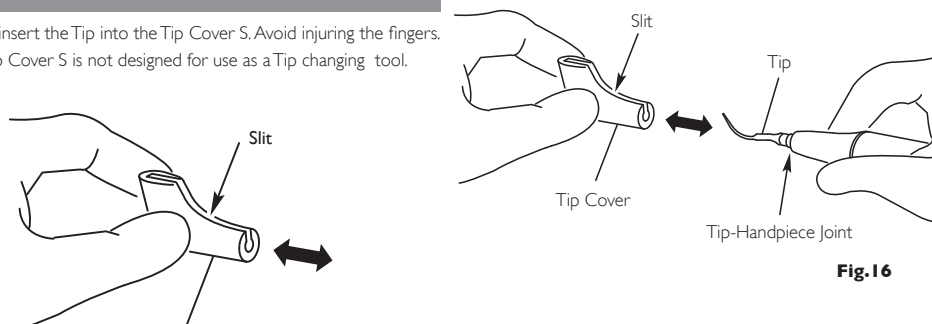

Fig. 16

9. HOLDER

9-1 HANDPIECE HOLDER

While the Handpiece is not in use, put the Handpiece on the Handpiece Holder: **(Fig. 17)**

⚠ NOTICE

To prevent injury, always mount Scaler Tip Cover S.

9-2 TIP HOLDER (OPTION)

When a Tip is removed from the handpiece, use the Tip Holder for storage. The Tip Holder is Autoclavable and holds up to 5 tips at once. To Autoclave, tilt the tips in the direction of the arrow. **(Fig. 18)**
(Reference section II for sterilization)

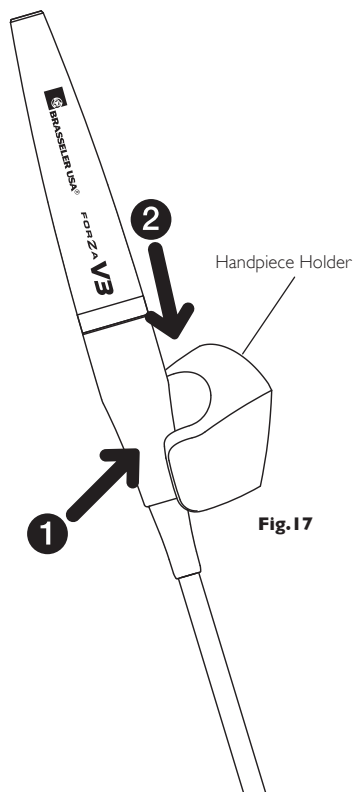
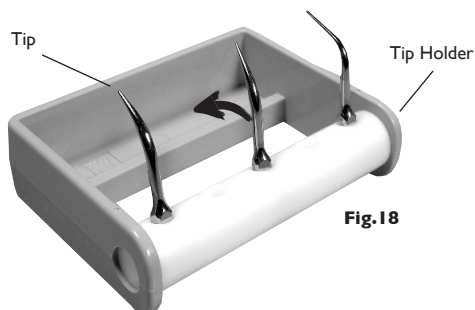

10. CARE AND MAINTENANCE

10-1 CLEANING OF OPTIC FIBER (FORZAV3 LED)

Wipe the debris off the end of the Optic Fibers at the handpiece with alcohol soaked cotton swab. **(Fig. 19)**

⚠ CAUTION

Do not use any sharp pointed tools to clean the Optic Fiber End Face. If the light is not working, contact Brasseler USA.

10-2 CHANGING O-RING

An O-Ring is located in the Handpiece Cord Connector. Use a pointed tool to remove, and mount new O-Ring into the groove. **(Fig. 20)**

* O-Ring Order Code 0310020080

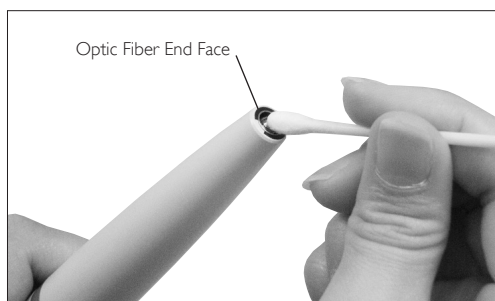

Fig.19



Fig.20

10-3 CHANGING WATER FILTER

Change the Water Filter as necessary.

- 1) Close the water valve of the Chair Unit.
- 2) Mount two Spanner Wrenches (5x8) and turn. **(Fig.21)**
- 3) When the Water Filter case is separated, the Water Filter can be removed. **(Fig. 22)**
- 4) Replace with new (Order Code 5010480U0) and reassemble the filter in the reverse order.

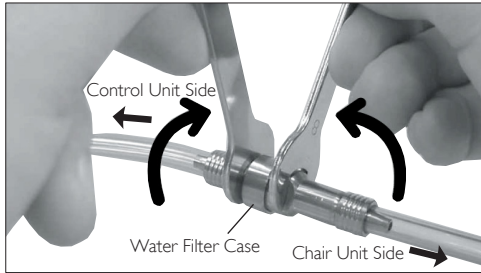

Fig.21

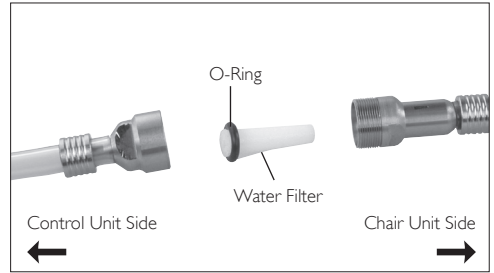

Fig.22

11. STERILIZATION

- Autoclave sterilization is recommended.
- Autoclave sterilization required first time you use and after each patient as noted below. Take handpiece out of the packing bag before sterilization.
- ONLY the Tip (except diamond coated scaler tip), Handpiece, Tip Wrench, Tip Holder and Tip Cover S can be autoclaved.



This handpiece can be cleaned and disinfected with a Thermo-Disinfectant.

■ Autoclave Procedure

- 1) Remove the Tip after use. (Refer to 5. Mounting and Removing Tip)
 - 2) Wipe dirt and debris from the products, and wipe clean with alcohol-immersed cotton swab or cloth. Do not use a wire brush.
 - 3) Insert instruments into an autoclave pouch. Seal the pouch.
 - 4) Autoclavable up to max. 135°C (275° F).
- Ex.) Autoclave for 20 min. at 121°C (249.8° F) or 15 min. at 132°C (269.6° F).

Steam Sterilization Cycle				
Type	Gravity Displacement			Pre-Vacuum
Minimum Temperature	121° C	132° C	135° C	135° C
Full Cycle Time	20 Minutes	15 Minutes	10 Minutes	10 Minutes
Minimum Dry Time	10 Minutes	10 Minutes	10 Minutes	15 Minutes

- 5) Keep the products in the autoclave pouch to keep it clean until you use it.

* Sterilization at 121°C for more than 15 minutes is recommended by ISO17664 and EN ISO17665-1.

The recommended sterilization procedures require the use of FDA-cleared sterilizers, sterilization trays, sterilization wraps, biological indicators, chemical indicators, and other sterilization accessories labeled for the sterilization cycle recommended.

⚠ CAUTION





- Do not sterilize by ultraviolet ray. The handpiece could discolor.
- If autoclaved with other instruments stained with chemical solution, it could strip the plating and make the surface black.
- Do not autoclave the Control Unit, AC Adaptor; Foot Control, Handpiece Cord, O-Rings. Perform alcohol disinfection to the Control Unit, AC Adaptor; Foot Control, Handpiece Cord after every patient.
- Do not wipe with, or clean or immerse in, high acid water or sterilizing solutions.

12. TROUBLESHOOTING

When problem occurs, please review the following list prior to contacting Brasseler USA.







PROBLEM	PROBABLE CAUSE	CAUSE	SOLUTION
No / Poor vibration	The Power Indicator is not on, even when the power is ON	The AC Adaptor or the DC Plug is disconnected	Correctly insert the AC Adaptor or the DC Plug
		The Tip does not generate vibration, even when depressing the Foot Control	The Tip is not tightened firmly
	Worn Tip		Replace the Tip
	Power has not been correctly adjusted for the Tip		Adjust the power level as indicated in the Power Guide or Tip Case label. Do not exceed MAX.
	The Foot Control is disconnected		Connect the Foot Control correctly
	Failure of vibrator in the handpiece	Contact Brasseler USA	
Failure of internal components of the Foot Control		Contact Brasseler USA	
The Tip is bent or broken	—	Power has not been properly adjusted for the Tip	Adjust the power level as indicated in the Power Guide or Tip case label. Do not exceed
The Tip is flying away	—	The Tip is not tightened firmly	Tighten the Tip until the Tip Wrench clicks
Noise from the handpiece	—	Power has not been properly adjusted for the Tip	Adjust the power level as indicated in the Power Guide or Tip case label. Do not exceed
		The Tip is not tightened firmly	Tighten the Tip until the Tip Wrench clicks
		Failure of vibration in the handpiece or the Control Unit	Contact Brasseler USA
The handpiece is overheating	—	Power has not been properly adjusted for the Tip	Adjust the power level as indicated in the Power Guide or Tip case label. Do not exceed MAX.
		The Tip is not tightened firmly	Tighten the Tip until the Tip Wrench clicks
		Failure of vibration in the handpiece or the Control Unit	Contact Brasseler USA
No / Poor water	The water does not reach the Control Unit	—	Check the water circuitry and supply to the Control Unit. Water pressure : 0.1-0.5MPa (1-5kgf/cm ²)
	Check to see if water reaches the Control Unit	The Water Adjustment Knob is closed.	Turn the Water Volume Knob and adjust to the appropriate volume
		Disconnected Irrigation supply at low volume range. (less than 10ml/min.)	No problem. Turn the Water Volume Knob and increase the Irrigation volume
		The Water Filter is clogged	Replace with new Water Filter (Refer to 10-3) Changing Water Filter
Water leakage	Water is leaking from the joint between the handpiece and the cord	O-Ring at the handpiece cord is worn or damaged	Replace with new O-Ring (Refer to 10-2 Changing O-Ring Handpiece Cord)
Attachment of the Control Unit Holder is loose	—	The holder locking mechanism is worn out.	Contact Brasseler USA
Handpiece LED does not illuminate. (Forza V3 LED)	Tip oscillates, but Handpiece LED turns on and off	The handpiece is not connected into the Handpiece Cord correctly	Firmly insert the handpiece into the Handpiece Cord.
Loss of the power output without operation	Power output is set 8 at G	Safety function is activated	Powerful output will weaken automatically when used continuously for over 10 minutes at maximum power in the G mode. Release the foot from the Foot Control. Decrease the Power less than 5, then increase the power again. (Refer to 7-5)

13. SPARE PARTS

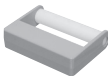
MODEL	PRODUCTS	ORDER CODE
Water Tube Set		5010478U0
Water Supply Connector		5010477U0
Water Filter		5010480U0
Spanner Wrench (5x8) X 2 pcs		Y1001301
Tip Wrench (CR-10)	 	5019770U0



Autoclavable up to max 135°C.

MODEL	PRODUCTS	ORDER CODE
Tip Holder	 	5010485U0
Tip Cover S	 	5010487U0
O-Ring		0310020080
Double-Face Tape (For Control Unit Holder)		20002545
Double-Face Tape (For Handpiece Holder)		20002544











14. DISPOSING PRODUCT

Dispose of product or recycle in accordance with local laws and regulations.

15. WARRANTY

Brasseler USA warrants the Forza V3 Ultrasonic System against defects in manufacturing, workmanship and materials for a period of one year. Brasseler USA reserves the right to analyze and determine the cause of any problem. Warranty is voided should the handpiece not be used in accordance with this manual. Expendable items such as O-Rings are not covered by this warranty.

16. SYMBOLS

	TUV Rhineland of North America is a Nationally Recognized Testing Laboratory (NRTL) in the United States and is accredited by the Standards Council of Canada to certify electro-medical products with Canadian National Standards.		Follow the waste of electric and electronic equipment (WEEE) Directive (2002/96/EC) to dispose of the product and accessories.
	Consult operation instructions.		Marking on the outside of Equipment or Equipment parts that include RF transmitters or that apply RF electromagnetic energy for diagnosis or treatment.
	Protected against vertically falling water drops.		Autoclavable up to Max. 135°C. * for detail see Sterilization.
	Type BF applied part.		Manufacturer
	Class II Equipment.		This product can be cleaned and disinfected with a Thermo-Disinfecter.
RX ONLY U.S. Federal law restricts this device to sale by or on the order of a dentist.			

GUIDANCE AND MANUFACTURER'S DECLARATION - ELECTROMAGNETIC EMISSIONS

The Forza V3/Forza V3 LED is intended for use in the electromagnetic environment specified below. The customer or the user of the Forza V3/Forza V3 LED should assure that is used in such an environment.

EMISSIONS TEST	COMPLIANCE	ELECTROMAGNETIC ENVIRONMENT - GUIDANCE
RF emissions CISPR11/EN55011	Group 1	The Forza V3/Forza V3 LED uses RF energy only for its internal function. Therefore, its RF emissions are very low and are not likely to cause any interference in nearby electronic equipment.
RF emissions CISPR11/EN55011	Class B	The Forza V3/Forza V3 LED is suitable for use in all establishments, including domestic establishments and those directly connected to the public low-voltage power supply network that supplies buildings used for domestic purposes.
Harmonic emissions EN/IEC61000-3-2	Class A	
Voltage fluctuations/flicker emissions EN/IEC61000-3-3	Complies	

GUIDANCE AND MANUFACTURER'S DECLARATION - ELECTROMAGNETIC IMMUNITY

The Forza V3/Forza V3 LED is intended for use in the electromagnetic environment specified below. The customer or the user of the Forza V3/Forza V3 LED should assure that is used in such an environment.

IMMUNITY TEST	EN/IEC60601 TEST LEVEL	COMPLIANCE LEVEL	ELECTROMAGNETIC ENVIRONMENT - GUIDANCE
Electrostatic discharge (ESD) EN/IEC61000-4-2	±6kV contact ±8kV air	±6kV contact ±8kV air	Floors should be wood, concrete or ceramic tile. If floors are covered with synthetic material, the relative humidity should be at least 30%.
Electrical fast transient/burst EN/IEC61000-4-4	±2kV for power supply lines ±1kV for input/output	±2kV for power supply lines ±1kV for input/output	Mains power quality should be that of a typical commercial or hospital environment.
Surge EN/IEC61000-4-5	±1kV line(s) to line(s) ±2kV line(s) to earth	±1kV line(s) to line(s) ±2kV line(s) to earth	Mains power quality should be that of a typical commercial or hospital environment.
Voltage dips, short interruptions and voltage variations on power supply input lines EN/IEC61000-4-11	<5% Ut (>95% dip in Ut) for 0.5 cycle 40% Ut (60% dip in Ut) for 5 cycles 70% Ut (30% dip in Ut) for 25 cycles <5% Ut (>95% dip in Ut) for 5 secs	<5% Ut (>95% dip in Ut) for 0.5 cycle 40% Ut (60% dip in Ut) for 5 cycles 70% Ut (30% dip in Ut) for 25 cycles <5% Ut (>95% dip in Ut) for 5 sec	Mains power quality should be that of a typical commercial or hospital environment. If the user of the Forza V3/Forza V3 LED requires continued operation during power mains interruptions, it is recommended that the Forza V3/Forza V3 LED be powered from an uninterruptible power supply or a battery.
Power frequency (50/60Hz) magnetic field EN/IEC61000-4-8	3 A/m	3 A/m	Power frequency magnetic fields should be at levels characteristic of a typical location in a typical commercial or hospital environment.

NOTE: Ut is the a.c. mains voltage prior to application of the test level.

GUIDANCE AND MANUFACTURER'S DECLARATION - ELECTROMAGNETIC IMMUNITY

The Forza V3/Forza V3 LED is intended for use in the electromagnetic environment specified below. The customer or the user of the Forza V3/Forza V3 LED should assure that it is used in such an environment.

IMMUNITY TEST	EN/IEC60601 TEST LEVEL	COMPLIANCE LEVEL	ELECTROMAGNETIC ENVIRONMENT - GUIDANCE
Conducted RF EN/IEC61000-4-6 Radiated RF EN/IEC61000-4-3	3Vrms 150 kHz to 80MHz 3V/m 80MHz to 2.5 GHz	3Vrms 3V/m	Portable and mobile RF communications equipment should be used no closer to any part of the Forza V3/Forza V3 LED, including cables, than the recommended separation distance calculated from the equation applicable to the frequency of the transmitter. Recommended separation distance $d = 1.2 \sqrt{P}$ $d = 1.2 \sqrt{P}$ 80MHz to 800MHz $d = 2.3 \sqrt{P}$ 800MHz to 2.5GHz Where P is the maximum output power rating of the transmitter in watts (W) according to the transmitter manufacturer and d is the recommended separation distance in meters (m). Field strengths from fixed RF transmitters as determined by an electromagnetic site survey, should be less than the compliance level in each frequency range. Interference may occur in the vicinity of equipment marked with the following symbol:

NOTE 1 At 80MHz and 800MHz, the higher frequency range applies.

NOTE 2 These guidelines may not apply in all situations. Electromagnetic propagation is affected by absorption and reflection from structures, objects and people.

a Field strengths from fixed transmitters, such as base stations for radio (cellular/cordless) telephones and land mobiles radios, amateur radio, AM and FM radio broadcast and TV broadcast cannot be predicted theoretically with accuracy. To assess the electromagnetic environment due to fixed RF transmitters, an electromagnetic site survey should be considered. If the measured field strength in the location in which the Forza V3/Forza V3 LED is used exceeds the applicable RF compliance level above, the Forza V3/Forza V3 LED should be observed to verify normal operation. If abnormal performance is observed, additional measures may be necessary, such as reorienting or relocating the Forza V3/Forza V3 LED.

b Over the frequency range 150kHz to 80MHz, field strengths should be less than 3V/m.

CABLES AND ACCESSORIES	MAXIMUM LENGTH	COMPLIES WITH	
Handpiece cord Foot Control AC Adaptor	2 m 5 m 5m	RF emissions, CISPR 11, EN55011 Harmonic emissions, Voltage fluctuations/ flicker emission, Electrostatic discharge (ESD) Electric fast transient / burst Surge Voltage dips, short interruptions and voltage variations on power supply input lines Power frequency(50/60Hz) magnetic field Conducted RF Radiated RF	Class B/ Group 1 EN/IEC61000-3-2 EN/IEC61000-3-3 EN/IEC61000-4-2 EN/IEC61000-4-4 EN/IEC61000-4-5 EN/IEC61000-4-11 EN/IEC61000-4-8 EN/IEC61000-4-6 EN/IEC61000-4-3

Recommended separation distances between portable and mobile RF communications equipment and the Forza V3/Forza V3 LED.

The Forza V3/Forza V3 LED is intended for use in an electromagnetic environment in which radiated RF disturbances are controlled. The customer or the user of the Forza V3/Forza V3 LED can help prevent electromagnetic interference by maintaining a minimum distance between portable and mobile RF communications equipment (transmitters) and the Forza V3/Forza V3 LED as recommended below, according to the maximum output power of the communications equipment.

Rated maximum output power of transmitter W	Separation distance according to frequency of transmitter m		
	150kHz to 80MHz $d=1.2 \sqrt{P}$	80MHz to 800MHz $d=1.2 \sqrt{P}$	800MHz to 2.5GHz $d=2.3 \sqrt{P}$
0.01	0.12	0.12	0.23
0.1	0.38	0.38	0.73
1	1.2	1.2	2.3
10	3.8	3.8	7.3
100	12	12	23

For transmitters rated at a maximum output power not listed above, the recommended separation distance d in meters (m) can be estimated using the equation applicable to the frequency of the transmitter, where P is the maximum output power rating of the transmitter in watts (W) according to the transmitter manufacturer.

NOTE 1: At 80 MHz and 800 MHz, the separation distance for the higher frequency range applies.

NOTE 2: These guidelines may not apply in all situations. Electromagnetic propagation is affected by absorption and reflection from structures, objects and people.

By Your Side in Dentistry



BRASSLER USA[®]
DENTAL INSTRUMENTATION

One Brasseler Boulevard, Savannah, GA 31419
To order call 800.841.4522 or fax 888.610.1937.
Visit our website: BrasselerUSA.com